

Flanged End Connection



Series C Carbon Steel

- Swing Check Valve
- ANSI Class 150 (285 PSI WP)
- 2" Through 6"
- Bolted Body Construction

- Replaceable Seat Disc Cartridge
- Seal Located in Seat, Thus Protected From Flow
- NACE Standard
- Stainless Steel Disc and Seat Standard

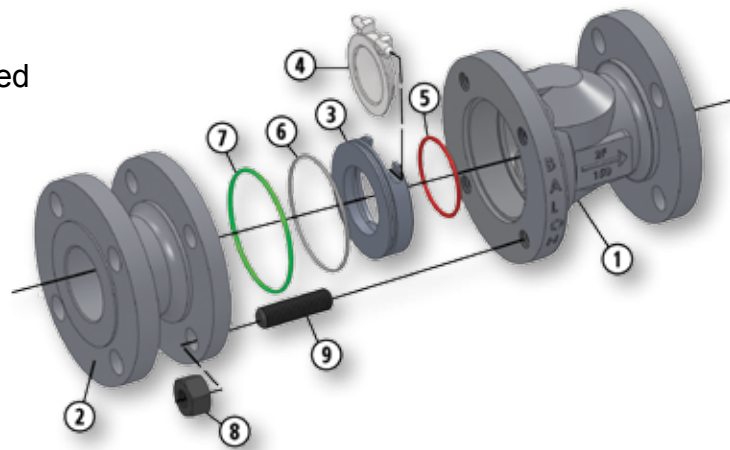

Material Description

ITEM	PART NAME	DESCRIPTION
1	Body	ASTM A216 WCB
2	Adapter	ASTM A216 WCB
3	Seat	Replaceable 316 Stainless Steel
4	Disc	Replaceable 316 Stainless Steel
5	O-Ring	Seat Seal: Fluorocarbon
6	O-Ring	Assembly Seal: Fluorocarbon
7	O-Ring	Body Seal: Fluorocarbon
8	Nuts	ASTM A194 2HM
9	Body Bolts	ASTM A193 B7M

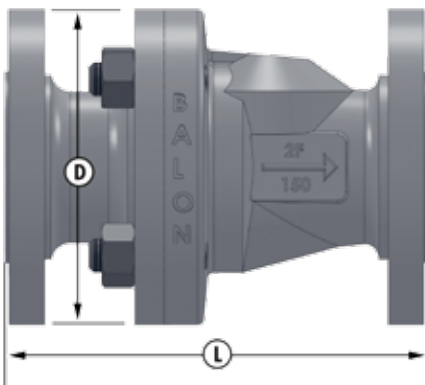

Dimensional Data

SIZE	CATALOG	PORT	D	L	LBS.
2	2F-C13S-RF	2	6	8	27
3	3F-C13S-RF	3	7.50	9.5	48
4	4F-C13S-RF	4	9	11.5	74
6	6F-C13S-RF	6	12.75	14	162